



A New RF Millivoltmeter for Convenient Measurements to 1 Kmc

THE greatly increasing use of transistors and, more recently, the introduction of the tunnel diode, have placed increased emphasis on low-level rf voltage measurement. In many applications, a convenient broadband laboratory and production tool is needed to replace cumbersome tuned receiver equipment. Measurement of the alpha cut-off of a transistor, the gain-bandwidth of a vacuum tube and the characteristics of a transmission line or filter network are a few examples.

To meet this need, the new -hp- Model 411A RF Millivoltmeter shown in Figure 1 has been developed. This high-sensitivity instrument provides accurate voltage measurements from 500 kc up to 1 kmc and gives useful voltage indications to as high as $3\frac{1}{2}$ kmc. This bandwidth, coupled with full scale sensitivities from 10 millivolts to 10 volts, gives the engineer working with high frequencies a powerful tool for investigating circuit operation.

A special convenience in an rf voltmeter of this wide range is the linear meter scale which minimizes reading errors and gives maximum resolution. In addition, a temperature compensated detector probe results in low calibration drift, even on the most sensitive range, so that accurate measurements in the millivolt range can be made with confidence.

To enable the instrument to drive a dc strip-chart or X-Y recorder, a recorder output jack is provided at the rear of the cabinet. This output allows automatic plotting of frequency characteristics that would normally require laborious point-by-point measurement. Fig. 2, for example, shows a plot made with this output of the frequency response of a 30-mc i-f amplifier at various gain settings. The voltmeter output is a current proportional to the meter deflection and is designed to operate into a 1000-ohm galvanometer. Galvanometers of other impedances from 0 to 5000 ohms can also be used, a calibrating control



Fig. 1. New -hp- Model 411A RF Millivoltmeter makes sensitive voltage measurements to 1 kilomegacycle with -hp- coax tee (foreground) and gives useful voltage indications to above 3 kilomegacycles. If desired, sweep-frequency voltage measurements can be recorded, as in Fig. 2, using dc output provided by 411A.

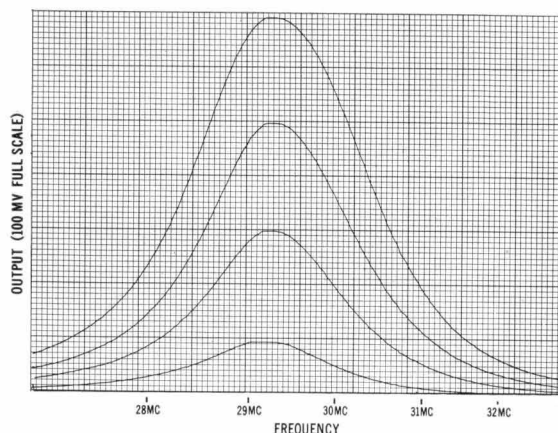

Fig. 2. Permanent records of frequency characteristics can readily be made using recorder jack provided on new 411A vtvm. Above recording shows curves made using 411A to measure frequency response of i-f amplifier at various gain settings.



Fig. 3. -hp- Model 411A RF Millivoltmeter. Probe is arranged to accommodate many measurement conditions since basic probe tip with flange-operated alligator jaws as shown is removable; probe can then use various specially-designed accessories such as rf fittings for measurements in coax cables.

being provided for accommodating such a range. High input impedance voltage recorders can be operated by shunting their inputs down to 1000 ohms. The response at the recorder output jack to a step change in rf level at the instrument's input is shown in Fig. 4. Freedom from excessive overshoot is evident, while the speed of response is adequate for recording typical variations in the amplitude of CW signals.

The general usability of the instrument is further enhanced by four accessory probe tips which allow convenient measurement in many different kinds of circuits. In addition to the pen-size probe tip supplied with every instrument, various accessory coaxial probe tips and a 100:1 capacitive divider are available.

DETECTION CONSIDERATIONS

Conventional rf voltmeters consist of a diode detector feeding a dc amplifier whose output is applied to a metering circuit. In this type of circuit the diode that operates as the detector element is quite important, since the resultant r-f performance depends heavily on the diode's characteristics. In many applications, a thermionic vacuum diode can be used with excellent results. It provides a high input impedance, wide frequency response and good calibration stability. In low-level measurements, however, drift in emission voltage of the thermionic diode limits its use. With no rf input to the diode, some electrons will reach the anode due to their initial emission velocity. As they accumulate at the anode, a negative voltage will be developed

which is just sufficient to overcome the initial electron energy and stop the electron current flow. This "emission voltage" varies with filament temperature, with time and from tube to tube, and variations in it are sufficiently large to mask the detected output of a low-level rf signal.

In low level measurement a semiconductor diode can replace a vacuum diode with at least two significant advantages. First, a semiconductor diode can more easily have a higher frequency response, principally because of the smaller dimensions involved. Secondly, the dc drift of a dark junction is determined primarily by thermocouple effects, allowing detection at much lower levels than that possible using a tube.

While these advantages make semiconductor diodes the more practical means for detecting low level rf, their detection characteristics are non-linear, changing from square law at the millivolt level to linear at high levels as shown in Fig. 5. Various methods have been used to compensate for this non-linearity. One method is the use of non-linear scales on the meter face. With this method, seven separate scales are required to cover a voltage range from 10 mv to 10 volts full scale in 10 db steps, resulting in poor resolution and a high probability of reading the wrong scale. Another solution is the inclusion of linearizing networks in the meter circuit, so that a linear meter scale can be used. The networks are

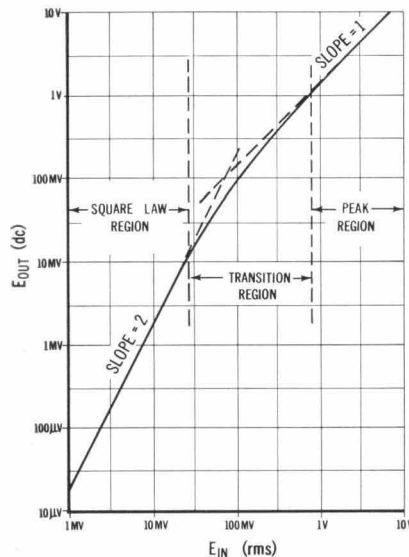

Fig. 5. Typical rectification characteristics of semi-conductor diode. To avoid the non-linear meter scales that normally result from non-linear rectification characteristic, 411A vtvm uses a circuit approach new to the voltmeter field.

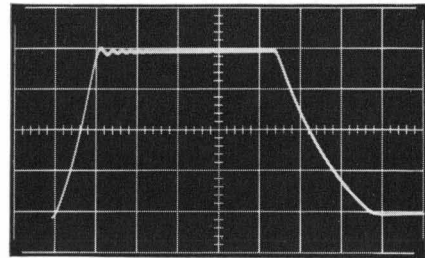

Fig. 4. Response at 411A output terminal to a full-scale burst of rf applied to 411A input. Sweep time is $\frac{1}{2}$ sec/cm; vertical scale is $\frac{1}{4}$ -volt/cm.

complex and a different one is required for each range. While both these methods are workable, overall calibration is difficult to maintain because of the substantial temperature dependence of the detector characteristics. Consequently, a different circuit approach has been pursued in the new voltmeter to achieve a linear meter scale in a more desirable way.

THE CIRCUIT

The approach used for the design of the 411A both overcomes the temperature problem and provides truly linear operation. Briefly, the arrangement is to generate, by use of feedback, a low-frequency sine wave whose amplitude is equivalent to that of the unknown input and to measure the amplitude of this low-frequency wave instead of that of the rf.

The general operation can be seen from the block diagram shown in Fig. 6. The input rf is detected by a semiconductor diode and the resulting dc signal fed into an error detector which, in the 411A, is a high-gain, chopper-stabilized dc amplifier. Any difference between the detected rf and the feedback reference is amplified and used to control the output of a suppressed-carrier modulator operating at 100 kc. The amplitude of the modulator output is proportional to the magnitude of the error, while the phase is determined by its polarity. The modulator output is fed back, through a range attenuator, to a second semiconductor diode whose detection characteristics are closely matched to those of the rf detector. The resulting dc is used as the reference for the error detector and, so long as the loop gain is high, the error will tend toward zero. Since the two detected dc voltages are approximately equal and the detection characteristics of the diode detectors are the same, the effective amplitude of the low frequency feedback signal must be equal to that

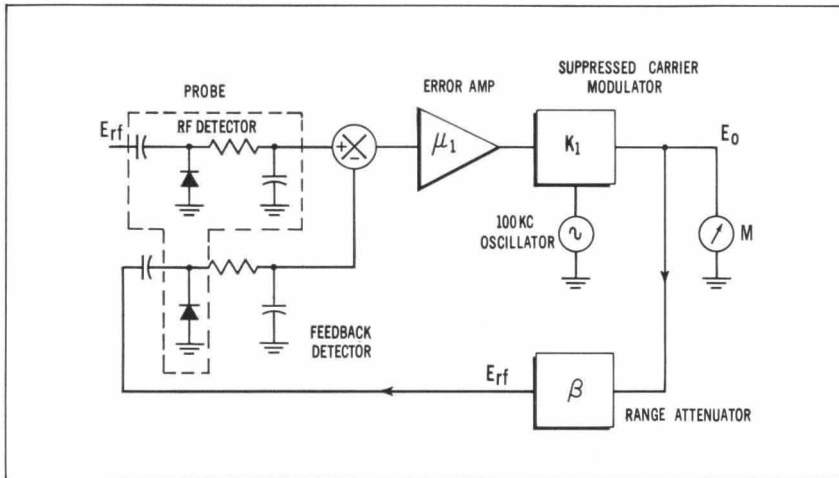

Fig. 6. Circuit arrangement of -hp- 411A RF Millivoltmeter. Feedback detector diode and rf detector diode have matched temperature characteristics and are located together in probe in thermal proximity to minimize drifts caused by thermal changes.

of the input rf. A measure of the amplitude of the feedback 100 kc thus becomes equivalent to a measure of the input rf, regardless of any non-linearity in the detector characteristics.

Because there are only two diodes to deal with, temperature compensation can be obtained by placing them in close thermal contact in the rf probe. Even though their characteristics change with temperature, they tend to change in the same manner so that match is maintained over a fairly wide temperature range. In the 411A, changes in calibration are negligible from 10°C to 40°C, and the instrument is usable with only slight reduction in accuracy from 0°C to 50°C.

ACCURACY

There are four principal factors which affect the overall accuracy of the 411A. They are the division accuracy of the range attenuator, the linearity of the 100 kc metering circuits, the diode match and the rf detector frequency response. Particular attention has been given to each of these to provide the highest accuracy over the widest possible frequency and temperature range.

For example, the range attenuator uses temperature-stabilized precision wirewound resistors which are matched to better than 1/4%. Metering is done at high level so that no amplification is needed outside the feedback loop. A ruggedized one milliamper meter movement with specially calibrated mirror-backed scale is used for maximum stability and resolution. The diodes are carefully matched at three different temperatures to insure tracking over a wide temperature range. And finally, the various probe tips have been designed to minimize possible errors due to measurement technique and variations in the circuit parameters of the rf detector. By using the appropriate probe tip, an overall full-scale accuracy of 3% can be obtained from 1 mc to 50 mc, 6% from 50 mc to 150 mc and 1 db from 500 Kc to 1000 mc.

ACCESSORY PROBE TIPS

A series of five probe tips is available to make full use of the instrument over its wide frequency range. The pen type tip supplied with every instrument uses the popular clip-on alligator jaws and provides convenient measurement in

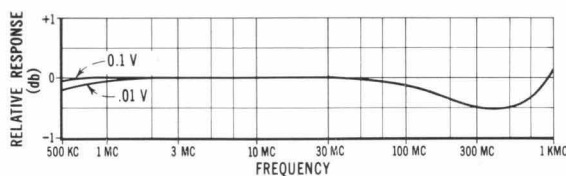
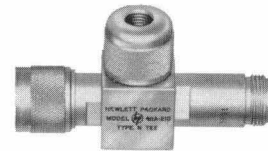

Fig. 7. Typical frequency response of -hp- 411A RF Millivoltmeter as used with -hp- 411A-21D Type N Tee. 411A can also be used as voltage indicator to about 3 1/2 kmc, since beyond 1 kmc frequency response characteristic typically exhibits a resonant rise of several db, peaking at about 2 1/2 kmc.



(a)

411A-21C VHF Probe replaces regular probe tip and extends frequency range of basic probe from 50 to 250 mc.



(b)

-hp- 411A-21D Type N Tee enables voltage measurements to be made in 50-ohm cables up to 1 kmc and voltage indications to above 3 kmc.



(c)

411A-21E BNC Probe enables measurements to be made to 500 mc in cables equipped with BNC jacks.

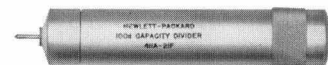

(d)

411A-21F Capacity Divider enables new vtvm to measure voltage up to 1,000 volts full scale, is usable to 250 mc.

Fig. 8. Accessory fittings for use with 411A vtvm.

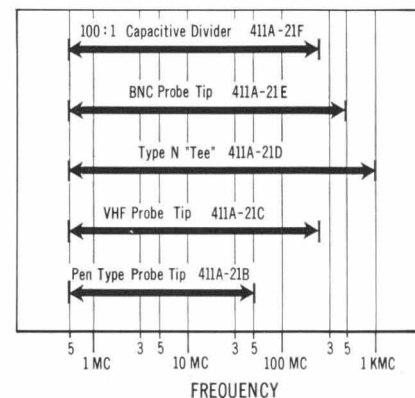

Fig. 9. Reference chart of frequency ratings for 411A accessories.

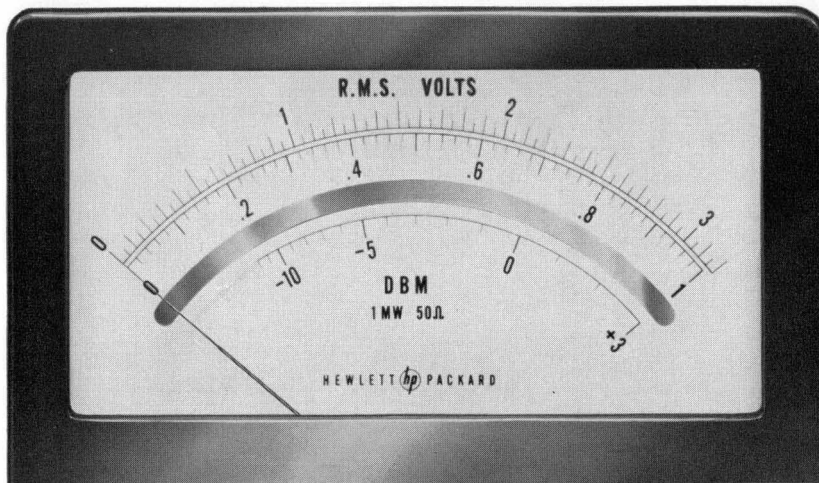

Fig. 10. Three-quarters scale reproduction of meter face used in new voltmeter.

open circuits such as the wiring in a high frequency amplifier. The blocking capacitor used is a high voltage, low leakage type allowing direct connection to points of high dc voltage. The frequency response is limited to 50 mc by the series resonance of input capacity of the detector diode with the inductance of the ground clip lead and the blocking capacitor. Although this resonance occurs at about 250 mc, the circuit Q is extremely high and can cause significant errors at frequencies above 50 mc.

The VHF Probe Tip (-hp- 411A-21C) has been designed to provide direct measurements at frequencies higher than those possible with the pen type probe. Typical applications are the alignment of RF and IF stages in a TV or FM receiver and the measurement of the frequency response of a distributed amplifier. In addition to providing a smaller input capacitance and shorter grounding paths than the pen type probe, the series resonant rise is damped out, allowing the VHF probe to be used at frequencies as high as 250 mc.

To measure voltages in coaxial lines, the 411A-21D Type N "Tee" and the 411A-21E BNC Open Circuit Probe-Tip have been developed. The Tee presents a VSWR of less than 1.15 at 1 kmc when terminated in 50 ohms and can be inserted directly into an rf line with minimum disturbance. The BNC probe-tip connects the voltmeter to a female BNC connector and makes possible the measurement of open-circuit voltages for such purposes as alignment or peaking.

In addition to the probe tips described above, a 100:1 capacitive divider (-hp- 411A-21F) is available. This divider extends the range of the 411A

to 1,000 volts full scale. The frequency range of the divider is from 500 kc to 250 mc, although as frequency increases, the divider is derated to limit the rf current flowing through its input capacitance.

DC PROTECTION

The size of the blocking capacitor in all the probe-tips has been selected to prevent damage to the rf detector diode. When the probe is first connected to a circuit containing a high dc voltage, a momentary surge of current flows through the diode to charge the blocking capacitor. While the peak value of the current pulse is unaffected by the size of the blocking capacitor, the area is. The pulse will last longer for a large value than for a small one and thus more junction heating will take place.

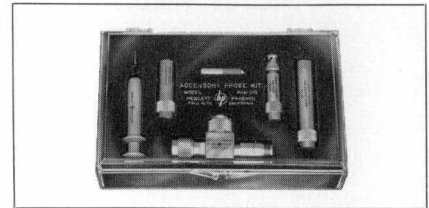

Fig. 11. Accessories are available as a kit (411A-21G) which also includes spare set of matched detector diodes.

If the value of the capacitor is too large, the diode detection characteristics may be changed, causing a mismatch with the feedback diode and reducing the accuracy of the instrument. In extreme cases the rf detector can even be destroyed. Since there is a probability of frequent contact with high dc potentials in the use of the 411A, a small blocking capacitor has been selected to protect the rf diode, even though the low frequency response of the unit could be improved by increasing its value. Repeated contact with potentials up to 300 vdc will not damage the diode or disturb the meter calibration.

RACK MOUNTING STYLE

Besides the cabinet version of the instrument shown in Fig. 1, a 7" high rack mounting version is also available.

DESIGN GROUP

Acknowledgment and appreciation are expressed to Hans O. Sorensen, Robert L. Huebner and John K. D. Lazier for their valuable assistance in the development and design of the 411A.

-Theodore C. Anderson

SPECIFICATIONS

-hp-

MODEL 411A

RF MILLIVOLTMETER

Voltage Range: 10 mv rms full scale to 10 volts rms full scale in seven ranges. Full scale readings of 0.01, 0.03, 0.1, 0.3, 1, 3, and 10 volts rms.

Frequency Range: 500 kc to 1 kmc with accessory probe tips. Usable indications to 3 1/2 kmc.

Accuracy: 1 mc to 50 mc, $\pm 3\%$ of full scale; 50 mc to 150 mc, $\pm 6\%$ of full scale; 500 kc to 1 kmc, 1 db.

Meter Scales: Two linear voltage scales, 0 to 1 and 0 to 3, calibrated in the rms value of a sine wave. DB scale, calibrated from +3 to -12 db; 0 db = 1 mw in 50 ohms.

Probe Tip Furnished: 411A-21B Pen Type Probe Tip, 500 kc to 50 mc. Shunt capacity: less than 4 pf. Maximum input: 300 vdc.

Galvanometer Recorder Output: Proportional to meter deflection, 1 ma into 1000 ohms at full scale deflection.

Power: 115/230 volts $\pm 10\%$, 50 to 60 cps, 35 watts.

Dimensions: Cabinet Mount: 11 3/4 in. high, 7 1/2 in. wide, 12 in. deep.

Rack Mount: 7 in. high, 19 in. wide, 10 3/8 in. deep behind panel.

ACCESSORIES AVAILABLE:

Probe Tips: 411A-21C VHF Probe Tip, 500 kc to 250 mc. Shunt Capacity: less than 2 pf. Maximum input: 300 vdc. Price: \$20.00.

411A-21D Type N "Tee" Probe Tip, 500 kc to 1 kmc. SWR is less than 1.15 when terminated in 50 ohms. Maximum input: 10 vdc. Price: \$40.00.

411A-21E BNC Open Circuit Probe Tip, 500 kc to 500 mc. Maximum input: 300 vdc. Price: \$17.50.

411A-21F 100:1 Capacity Divider Probe Tip, 500 mc to 250 mc. Division Accuracy: $\pm 1\%$; Shunt Capacity: 2 pf. Maximum input: 1000 volts pk (dc + pk ac). Price: \$35.00.

Probe Kit: 411A-21G Accessory Probe Kit. This kit includes the 411A-21C, 411A-21D, 411A-21E, 411A-21F Probe Tips and a replacement diode cartridge. Price: \$145.00.

Price: -hp- Model 411A RF Millivoltmeter, Cabinet Mount, \$450.00.

-hp- Model 411AR RF Millivoltmeter, Rack Mount, \$455.00.

Prices f.o.b. Palo Alto, California.

Data subject to change without notice.